



Spec Suites Available for Immediate Occupancy



Broker Incentive

5 Day/4 Night Trip for 2 to Mexico

- Location, dates selected by broker
- Full floor transaction or more
- Minimum 5 year term

REDUCED RATE
\$24.75/RSF

PNC Center

120 South Central Avenue
Clayton, Mo 63105

FEATURING

- High Level of Finish in Building Lobby
- Breve Espresso Cafe - Serves Breakfast & Lunch
- Building Fitness Center
- Three Building Conference Rooms
- Across from County Courthouse
- On-Site Building Management
- **Spec Suites 1275 (1,530 RSF) & 1550 (3,446 RSF) Available for Immediate Occupancy**

AVAILABILITY

FLOOR	SF
1ST	7,523
2ND	16,704
3RD	16,704
6TH	6,825
7TH	16,397
12TH (SPEC SUITE)	1,530
14TH	10,049
15TH (SPEC SUITE)	3,446

33,408 RSF CONTIGUOUS

FOR MORE INFORMATION PLEASE CONTACT:

Mike Carlson, CCIM, SIOR
mcarlson@sansonegroup.com

Brandon Wappelhorst
bwappelhorst@sansonegroup.com
314-727-6664

Floor Plans on Back



FLOOR PLANS

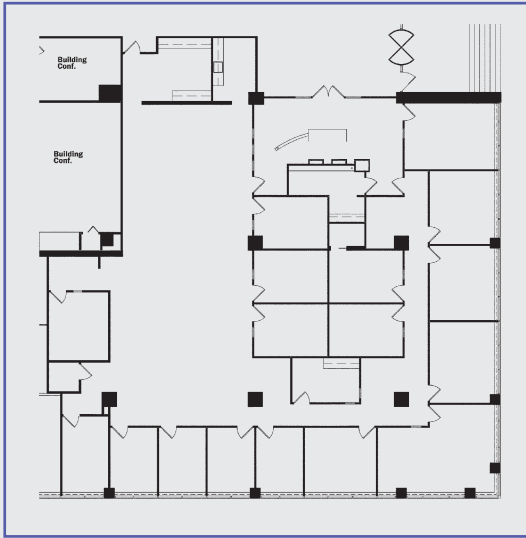

1st Floor 7,523 RSF

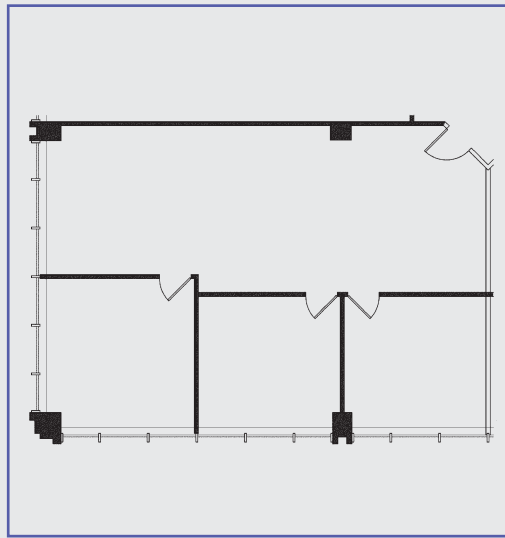

Spec Suite 1275 • 1,530 RSF

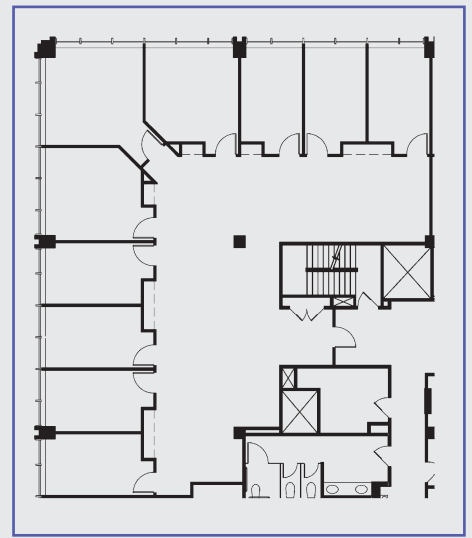

Spec Suite 1550 • 3,446 RSF

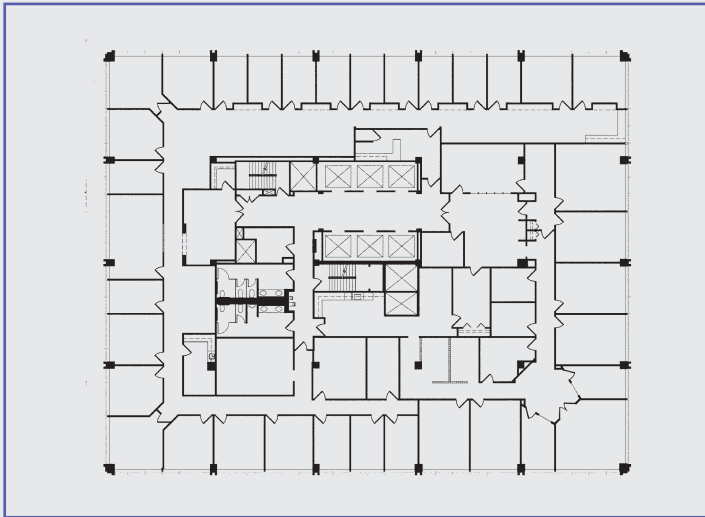

7th Floor 16,397 RSF

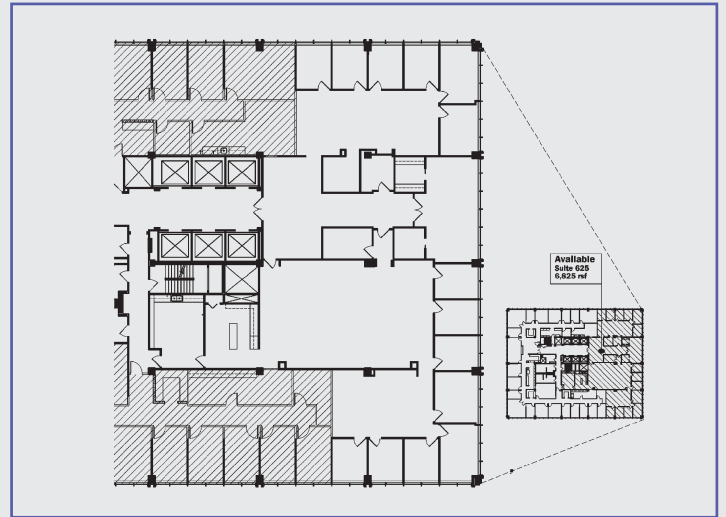

SUITE 625 6,825 RSF

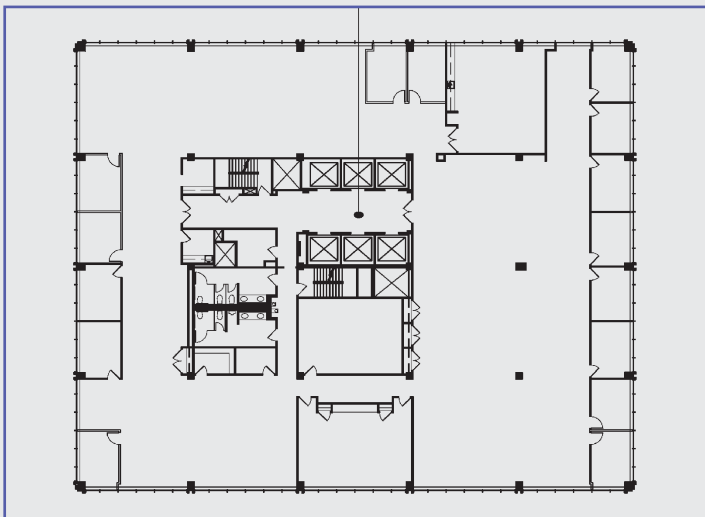

2nd Floor 16,704 RSF

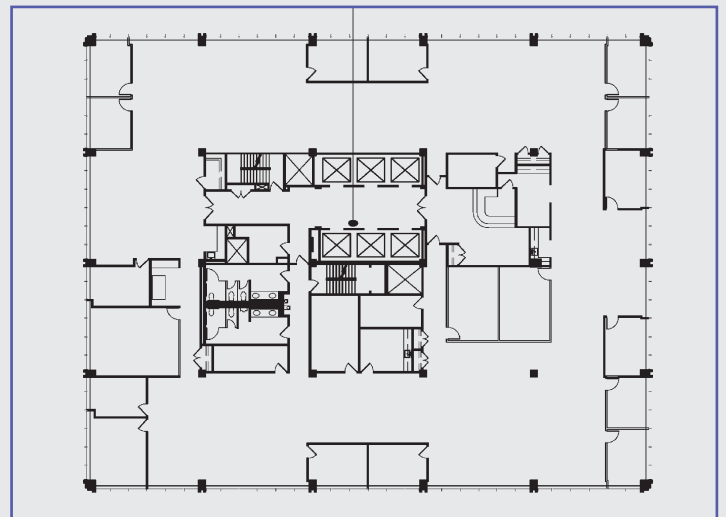

3rd Floor 16,704 RSF

{33,408 RSF Contiguous}